

## Overall



### ▼ Features

Track rollers LFR are double row angular contact ball bearings comprising an outer ring with a gothic arch profile, an inner ring and two ball and cage assemblies with plastic cages. The inner ring and outer ring are made from rolling bearing steel 100Cr6(52100) or stainless steel 1.4125(440C).

The track rollers series LFR can be used on round shafts with diameter from 4 mm to 50 mm.

The contact between track roller gothic arch groove profile and shaft is on two points. The contact angle is a maximum of 30°. The bearings can support axial forces from both directions as well as radial forces.

The track rollers are available with either shields ZZ or contact seals 2RS.

The units are supplied with lifetime grease lubrication (DIN 51825 K3N-30).

The sizes with an outside diameter 52 mm or greater have a lubrication hole in the inner ring.

To prevent mixing of greases with different characteristics, please insure to perform the lubrication of the units with lubricants that have the same characteristics as the grease used at the factory.

### ▼ Advantage of guide system that LFR track roller applied

#### High allowance speed, low resistance and long life

For series LFR rollers, the surface profile of the outer ring is designed as the GOTHIC ARCH. When rollers run, there are two contact points with an angle 60 degrees between the roller and track. So the friction resistance is low and the load is in equality thus avoiding the stresses centralization and edge effect caused by the error from installation and manufacturing, making the track system has the characteristics of high speed, low energy consumption, long service life and minimum noise level.

#### Easy installation

As rollers assembled the concentric or eccentric pivot, installation can be made conveniently. To adjust the eccentric one's eccentricity, these rollers can get the fitting preload.

#### Smooth running, minimum error and lower noise level

The high precision machinery and complete inspection facilities make accuracy in the profile of roller. Mature manufacturing techniques and critical inspection procedure make all rollers good in the Kea (radial runout) of outer ring and roundness of working surface, so the guide system in motion is smooth running, minimum error and lower running noise level.

### ▼ Application

- 1, Industrial machinery: printing machinery, paper machinery, automation machinery, textile machinery, vending machines, woodworking machinery, packaging machinery,
- 2, Electronic equipment: mechanical arm, measuring equipment, X-X platform, medical equipment, factory automation equipment;
- 3, Rotation machinery: metal heat treatment designed nuclear reactor, brakes, etc;
- 4, Aerospace industries: aircraft flaps brakes, seat brakes, missiles, airport apparatus and other equipment
- 5, Other: radio antenna brakes, door and window control, medical bed control, parking facilities, machine tool doors, laboratory automation, etc.

### ▼ Premium quality assurance

C&H Track Rollers are made from ultra clean steel. The dimensional tolerance is P6 class (ISO492). The run-out is P5 class (ISO492).

Shanghai chenghui (C&H) Bearing Co.,Ltd  
 2-1709, No 289, Zheqian Road, Pudong, Shanghai, China  
 Tel: +86 (0) 21 58356710 Fax: +86 (0) 21 58356720  
 E-mail: jason@chenghuibearing.com / chenghui-china.com

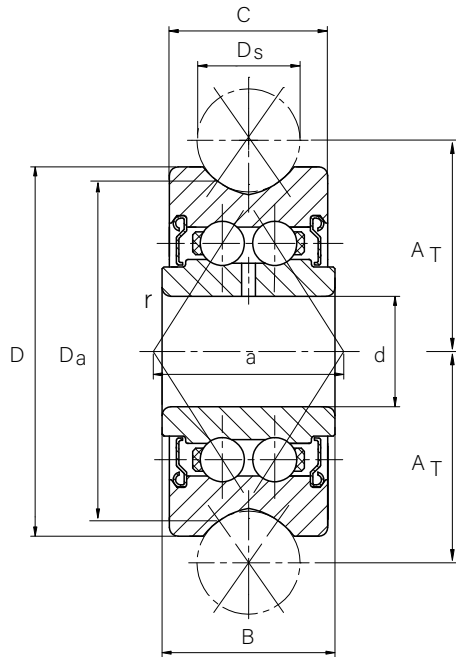

Material of different application track roller

Type	Outer Ring	Inner Ring	Balls	Cage	Shield Seal	Grease	Temp.Range
LFR...-2Z	100Cr6 52100	100Cr6 52100	100Cr6 52100	Nylon 66	SPCC	Kyodo Yushi Multemp SRL	-22°F to +212°F -30°C to +120°C
LFR...-2RS	100Cr6 52100	100Cr6 52100	100Cr6 52100	Nylon 66	NBR	Kyodo Yushi Multemp SRL	-22°F to +212°F -30°C to +120°C
SLFR...-2RS-H1	1.4125 440C	1.4125 440C	1.4125 440C	304	NBR	Klübersynth UH1 14-151	-22°F to +212°F -30°C to +100°C
SLFR...-2Z-227	1.4125 440C	1.4125 440C	1.4125 440C	304	304	Krytox GPL 227	-22°F to +500°F -30°C to +260°C
SLFR...-2Z-300	1.4125 440C	1.4125 440C	1.4125 440C	304	304	Klüber Isoflex PDL 300A	-94°F to +230°F -70°C to +110°C
SLFR...-2Z-VAC	1.4125 440C	1.4125 440C	1.4125 440C	304	304	Lubcon Ultratherm 2000	-31°F to +482°F -35°C to +250°C

Part Number	Dimensions (mm)							Load ratings (N)					Weight	Bolts Concentric	Bolts Concentric
	Linear shaft dia.	Bore dia.	Outside dia.	Inner ring width	Outer ring width	shaft center to bore center	Rad.	Effective dynamic load rating as track roller	Effective static load rating as track roller (radial)	Fatigue load limit	Maximum dynamic load rating as track roller	Maximum static load rating as track roller (radial)			
	d <sub>s</sub>	d	D	B	C	A <sub>T</sub>	r <sub>min</sub>	C <sub>DW</sub>	C <sub>0rw</sub>	C <sub>UR</sub>	F <sub>r per</sub>	F <sub>0r per</sub>			
LFR50/4-4-2Z	4	4	13	7	6	7.55	0.2	1050	850	43	1150	1600	0.007	-	-
LFR50/5-4-2Z	4	5	16	8	7	9	0.2	1560	850	43	1300	1700	0.009	LFZ5	LFE5-0.5
LFR50/5-6-2Z	6	5	17	8	7	10.5	0.2	1630	900	44.5	2230	1800	0.01	LFZ5	LFE5-0.5
LFR50/6-6-2Z	6	6	19	9	8.5	11.5	0.3	1630	900	44.5	2230	1800	0.013	LFZ5	LFE5-0.5
LFR50/8-6-2Z	6	8	24	11	11	14	0.3	4100	2300	115	2550	4600	0.02	LFZ8	LFE8-1
LFR50/8-8-2Z	8	8	24	11	11	14.75	0.3	4100	2370	118	2650	4750	0.02	LFZ8	LFE8-1
LFR5201-10-2Z	10	12	35	15.9	15.9	20.65	0.6	8300	5000	250	4500	8300	0.08	LFZ12	LFE12-1
LFR5201-12-2Z	12	12	35	15.9	15.9	21.75	0.6	8300	5000	250	4500	8200	0.085	LFZ12x45A1	LFE12x45A1
LFR5201-14-2Z	14	12	39.9	20	18	24	0.3	8900	5000	250	6700	12100	0.095	-	-
LFR5201-20-2Z	20	12	35	15.9	15.9	25.65	0.6	8300	5000	250	4500	8300	0.08	-	-
LFR5301-10-2Z	10	12	42	19	19	24	0.6	13200	7700	370	6100	11600	0.1	LFZ12/M12	LFE12-
LFR5301-20-2Z	20	12	42	19	19	28	0.6	13200	7700	370	6100	11600	0.13	-	-
LFR5202-12-2Z	12	15	45	15.9	15.9	26.5	0.6	11700	7000	350	7000	11700	0.12	-	-
LFR5302-10-2Z	10	15	47	19	19	26.65	1	14500	9100	455	9200	16700	0.17	LFZ15	LFE15-1
LFR5204-16-2Z	16	20	52	22.6	20.6	31.5	1	15300	10100	520	10000	17600	0.23	LFZ20x67A1	LFE20x67A1
LFR5206-20-2Z	20	25	72	25.8	23.8	41	1	23200	16500	870	20800	33000	0.43	LFZ25x82A1	LFE25x82A1
LFR5206-25-2Z	25	25	72	25.8	23.8	43.5	1	22700	16100	850	18800	32000	0.43	LFZ25x82A1	LFE25x82A1
LFR5207-30-2Z	30	30	80	29	27	51	1	28500	20800	1100	18000	31000	0.66	LFZ30x95A1	LFE30x95A1
LFR5208-40-2Z	40	40	98	38	36	62.5	1.1	38500	29000	1480	50000	58000	1.36	LFZ40x105A1	LFE40x105A1
LFR5308-50-2Z	50	40	110	46	44	72.5	1.1	54000	40500	2000	69000	81000	1.4	LFZ40x115A1	LFE40x115A1

Re-lubrication: Outer diameter ≥ 52 mm inner ring have a lubrication hole  
Accuracy :Tolerance: PN, P6, Runout: PN, P6 or P5; Clearance: CN

Interchange with original producer

Maker	Shields	Seals	Stainless Steel
C&H	Suffix " 2Z "	Suffix " 2RS "	Prefix " S "
INA	Suffix " NPP "	Suffix " KDD "	Suffix " X "
INA(NEW)	Suffix " 2Z "	Suffix " 2RS "	Suffix " RB "

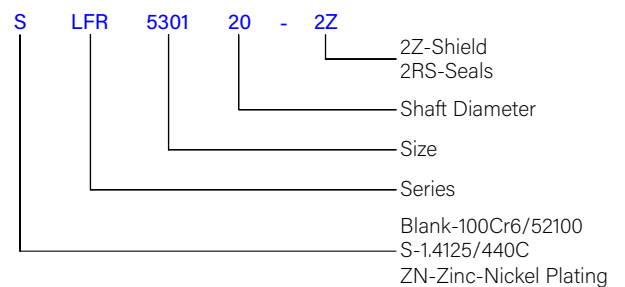

Shanghai chenghui (C&H) Bearing Co.,Ltd

2-1709, No 289, Zheqian Road, Pudong, Shanghai, China

Tel:+86 (0) 21 58356710 Fax: +86 (0) 21 58356720

E-mail: jason@chenghuibearing.com / chenghui-china.com

**Features**

The bolts are made from high strength screw steel, heat treated, standard is oxid black finish for corrosion protection. Zinc and Zinc-Nickel finish is also available. The bolts material are also available with stainless steel. They are available with a concentric and eccentric collar; designation LFZ or LFE. Depending on their intended purpose. They are supplied with a washer, nut, drive fit lubrication nipple and sealing cap, see table delivered condition. The eccentric designs LFE and LFE.-A1 allow the track roller guidance systems to be set clearance-free.

**Type and Delivery Conditions**

Designation	Included in delivery	Design
LFZ	Concentric bolt with washer	Standard
LFE	Eeccentric bolt with washer and nut	Standard
LFZ.-A1	Concentric and eccentric bolt with washer and nut, driving fit lubrication nipple and sealing cap	Standard
LFE.-A1	Concentric and eccentric bolt with washer and nut, driving fit lubrication nipple and sealing cap	Standard
NIP-A2	Drive fit lubrication nipple	Accessory
VD2	Sealing cap	Accessory

**Lubrication**

Bolts LFZ.-A1 and LFE.-A1 have a lubrication hole. A lubrication nipple NIP-A2 can be pressed into the hole. If the hole will not be used for relubrication, it must be closed off using the sealing cap VD2.

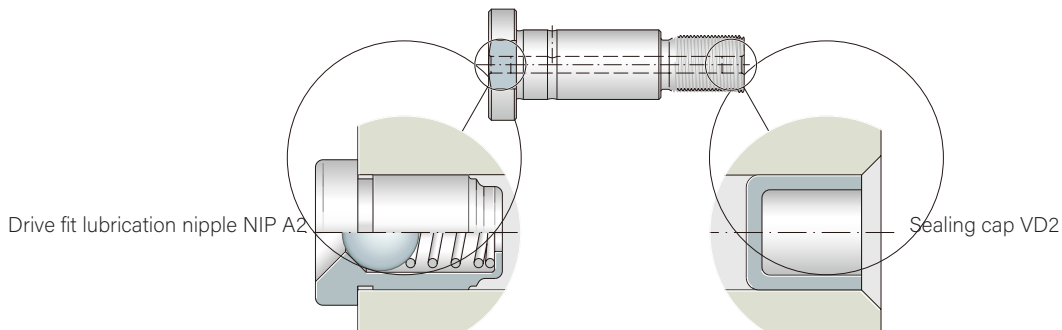

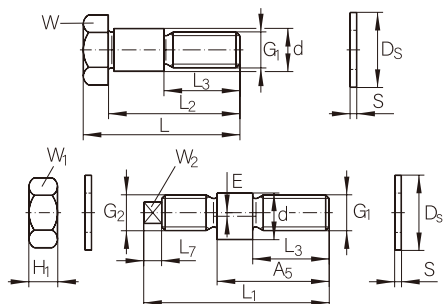

LFZ, LFE

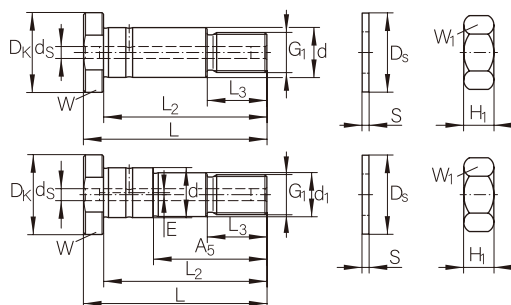

LFZ.-A1, LFE.-A1

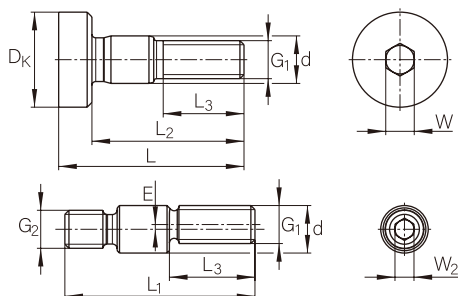

LFZ5 and LFE5-0.5



Designation	Dimensions (mm)																Width across flats (mm)			Mass m kg	
	d	G <sub>1</sub>	G <sub>2</sub>	L	L <sub>2</sub>	L <sub>3</sub>	L <sub>1</sub>	A <sub>5</sub>	L <sub>7</sub>	D <sub>s</sub>	E	H <sub>1</sub>	S	D <sub>K</sub>	d <sub>s</sub>	d <sub>1</sub>	W	W <sub>1</sub>	W <sub>2</sub>		
LFZ5	5	M4	-	19.5	16	9.5	-	-	-	-	-	-	-	10	-	-	3	-	-	0.01	
LFE5-0.5			M4	-	9	20.5	15	-	-	-	0.5	2.9	-	-	-	-	-	-	7		2
LFZ8	8	M8	-	28.3	24.3	15	-	-	-	14	-	-	1	-	-	-	12	-	-	0.02	
LFE8-1			M8X0.75	-	13.7	33.2	22	3.5	-	-	1	4	-	-	-	-	-	-	13		5
LFZ12	12	M10	-	43	36	22	-	-	-	21	-	-	1.8	-	-	-	17	-	-	0.04	
LFE12-1			M10	-	19.5	50	33.5	5	-	-	-	-	-	-	-	-	-	17	-		6
LFZ12/M12			-	50.8	43.8	24	-	-	-	19	-	-	-	-	-	-	-	17	-		-
LFE12-1/M12			M12	-	-	57	41	5	-	-	1	6.5	1.5	-	-	-	-	-	17		6
LFZ15	15	M12	-	50.8	43.8	26	-	-	-	21	-	-	2	-	-	-	19	-	-	0.06	
LFE15-1			M12	-	24	57	41	4	-	-	1	6.5	-	-	-	-	-	-	19		6
LFZ12X45-A1	12	M10X1.5	-	50	45	16	-	-	-	21	-	8	2	20	-	-	17	17	-	0.04	
LFE12X45-A1			-	-	-	30	-	-	-	0.75	-	-	-	-	-	-	-	10	-		-
LFZ20X67-A1	20	M16X1.5	-	75	67	23	-	-	-	30	-	13	3	30	5.9	-	27	24	-	0.2	
LFE20X67-A1			-	-	-	45	-	-	-	1	-	-	-	-	-	-	-	17	-		-
LFZ25X82-A1	25	M20X1.5	-	92	82	30	-	-	-	37	-	16	3	40	5.9	-	36	30	-	0.4	
LFE25X82-A1			-	-	-	57	-	-	-	1	-	-	-	-	-	-	-	22	-		-
LFZ30X95-A1	30	M24X1.5	-	107	95	32	-	-	-	44	-	19	4	45	5.9	-	41	36	-	0.62	
LFE30X95-A1			-	-	-	67	-	-	-	1	-	-	-	-	-	-	-	27	-		-
LFZ40X107-A1	40	M30X1.5	-	117	107	-	-	-	-	56	-	-	-	-	-	-	-	-	-	1.1	
LFE40X107-A1			-	-	-	42	-	-	-	1	-	24	4	55	5.9	-	36	-	-		
LFZ40X115-A1			-	-	-	-	-	-	-	-	-	-	-	-	-	-	-	-	-		-
LFE40X115-A1			125	115	-	-	-	-	-	72	-	-	-	-	-	-	-	36	46		46

1. LFZ5, LFE5-05 No washer required
2. LFE12X45-A1,LFE12X45-A1 Without Lubrication

**Interchange with Original producer**

Maker    Stainless Steel    For Example  
 C&H    Prefix " S "        SLFZ25X82-A1, SLFE5-0.5  
 INA     Suffix " RB "        LFZ25X82-A1-RB, SLFE5-05-RB

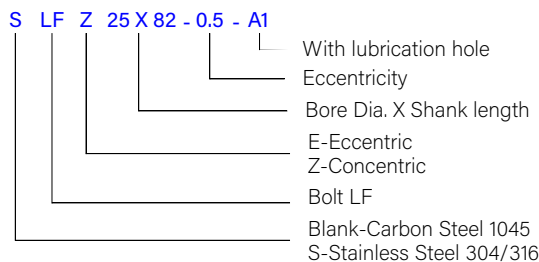

Shanghai chenghui (C&H) Bearing Co.,Ltd

2-1709, No 289, Zheqian Road, Pudong, Shanghai, China

Tel: +86 (0) 21 58356710 Fax: +86 (0) 21 58356720

E-mail: jason@chenghuibearing.com / chenghui-china.com

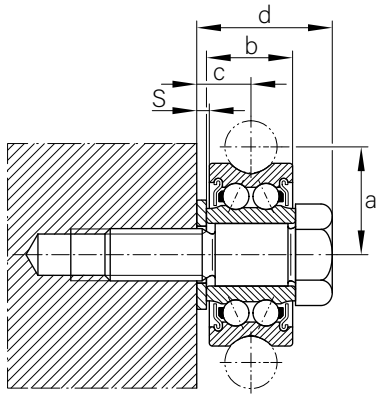

Locating bearing track roller	Bolt	a <sup>1)</sup>	b	S	c	d
LFR50/5-4-2Z <sup>2)</sup>	LFZ05	9	8	-	4	11.5
	LFE05-0.5					
LFR50/5-6-2Z	LFZ05	10.5	8	1	5	11.5
	LFE05-0.5					
LFR50/8-6-2Z	LFZ08	14	12	1	6.5	16
	LFE08-1					20.5
LFR5201-10-2Z	LFZ12	20.65	17.7	1.8	9.7	24.7
	LFE12-1					32.3
LFR5301-10-2Z	LFZ12/M12	24	20.8	1.8	11.3	27.8
	LFE12-1/M12					34.8
LFR5302-10-2Z	LFZ15	26.65	21	2	11.5	28
	LFE15-1					35
LFR5201-12-2Z	LFZ12X45-A1	21.75	17.9	2	9.9	22.9
	LFE12X45-A1					
LFR5204-16-2Z	LFZ20X67-A1	31.5	25.6	3	14.3	33.6
	LFE20X67-A1					
LFR5206-20-2Z	LFZ25X82-A1	41	28.8	3	15.9	38.8
	LFE25X82-A1					
LFR5206-25-2Z	LFZ25X82-A1	43.5	28.8	3	15.9	38.8
	LFE25X82-A1					
LFR5207-30-2Z	LFZ30X95-A1	51	33	4	18.5	45
	LFE30X95-A1					
LFR5208-40-2Z	LFZ40X107-A1	62.5	42	4	23	52
	LFE40X107-A1					
LFR5308-50-2Z	LFZ40X115-A1	72.5	50	4	27	60
	LFE40X115-A1					

1) With eccentric bolts, the dimension a varies by E in accordance with the bolt catalog.

2) No washer required.

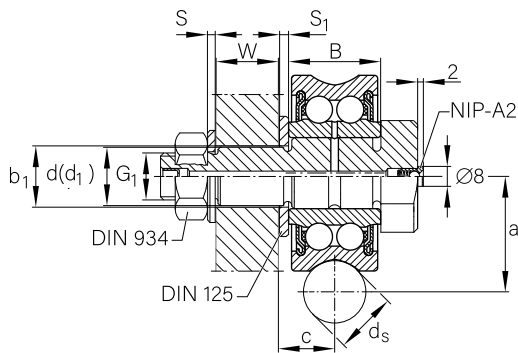

Locating bearing track roller	Bolt	a	c	d	d <sub>1</sub>	G <sup>1)</sup>	S <sup>2)</sup>	W <sup>3)</sup>	Washer DIN 125-A		dLW	B
									S <sub>1</sub>	b <sub>1</sub>		
LFR5201-12-2Z	LFZ12X45-A1	21,75	9,75	12	-	M10X1.5	2	12	2,5	13	12	15,9
	LFE12X45-A1			-	10				2	10,5		
LFR5204-16-2Z	LFZ20X67-A1	31,5	11,3	20	-	M16X1.5	3	20	3	21	20	22,6
	LFE20X67-A1			-	17				3	17		
LFR5206-20-2Z	LFZ25X82-A1	41	12,9	25	-	M20X1.5	3	25	4	27	20	25,8
	LFE25X82-A1			-	22				3	23		
LFR5206-25-2Z	LFZ25X82-A1	43,5	12,9	25	-	M20X1.5	3	25	4	27	25	25,8
	LFE25X82-A1			-	22				3	23		
LFR5207-30-2Z	LFZ30X95-A1	51	14,5	30	-	M24X1.5	4	32	4	31	30	29
	LFE30X95-A1			-	27				4	28		
LFR5208-40-2Z	LFZ40X107-A1	62,5	19	40	-	M30X1.5	4	40	6	41	40	38
	LFE40X107-A1			-	36				5	37		
LFR5308-50-2Z	LFZ40X115-A1	72,5	23	40	-	M30X1.5	4	40	6	41	40	46
	LFE40X115-A1			-	36				5	37		

1) For nuts in accordance with DIN 934, included in the scope of delivery.

2) For washers in accordance with DIN 125, included in the scope of delivery.

3) Recommended minimum wall thickness.

Shanghai chenghui (C&H) Bearing Co.,Ltd

2-1709, No. 289, Zheqian Road, Pudong, Shanghai, China

Tel: +86 (0) 21 58356710 Fax: +86 (0) 21 58356720

E-mail: jason@chenghuibearing.com / chenghui-china.com

# Stud Type Track Rollers

thru-hole type, gothic arch groove profile outer running surface

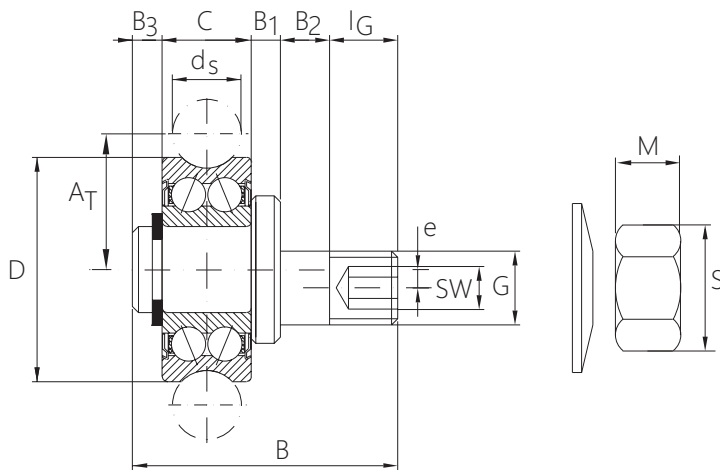

Part Number	Weight (g)	Dimensions (mm)													Load ratings(N)				Roller No	NIKO
		e	dw	D	C	A	B	B <sub>1</sub>	B <sub>2</sub>	B <sub>3</sub>	I <sub>G</sub>	SW	G	Dynamic load rating as track roller	Static load rating as track roller (radial)	Maximum dynamic load rating as track roller (radial)	Maximum static load rating as track roller (radial)			
														C	C <sub>0</sub>	F <sub>r</sub>	F <sub>0r</sub>			
SRAC051706	15	-	6	17	7	10.5	23	2	5	6	2	3	M5	1,250	850	1,250	1,700	LFR50/5-6-2Z	RPC17	
SRAE051706	15	0.5	6	17	7	10.5	23	2	5	6	2	3	M5	1,250	850	1,250	1,700	LFR50/5-6-2Z	RPE17	
SRAC082406	42	-	6	24	11	14.0	29	2.0	6.0	7.0	3	4	M8	3,500	2,200	1,250	4,350	LFR50/8-6-2Z	RPC24	
SRAE082406	42	0.5	6	24	11	14.0	29	2.0	6.0	7.0	3	4	M8	3,500	2,200	1,250	4,350	LFR50/8-6-2Z	RPE24	
SRAC103510	120	1	10	35	16	20.7	44	2.0	10.0	13.0	3	5	M10	8,100	4,900	4,900	9,700	LFR5201-10-2Z	RPC35	
SRAE103510	120	1	10	35	16	20.7	44	2.0	10.0	13.0	3	5	M10	8,100	4,900	4,900	9,700	LFR5201-10-2Z	RPE35	

## Note

Track rollers with integral studs are supplied with split washer and nut.

1. Standard sealing solution is shields on both side. Seals on request.
2. Standard grease is Kyodo Yushi Multemp SRL.
3. Tolerance: Normal ; Runout: below 0.02mm, Spacing hole tolerance not over  $\pm 0.2$ mm
4. Internal Clearance: Normal
5. Standard bolt material is 1045 carbon steel , clear Zinc plated. 303 stainless steel bolt is available on request.
6. 440C stainless steel version on request.
7. MOQ: 1000pcs.
8. Standard lead time: 60 days.

Shanghai chenghui (C&H) Bearing Co.,Ltd

2-1709, No 289, Zheqian Road, Pudong, Shanghai, China

Tel: +86 (0) 21 58356710 Fax: +86 (0) 21 58356720

E-mail: jason@chenghuibearing.com / chenghui-china.com

# Integral Studded Type Track Roller

gothic arch groove profile outer running surface and integral stud

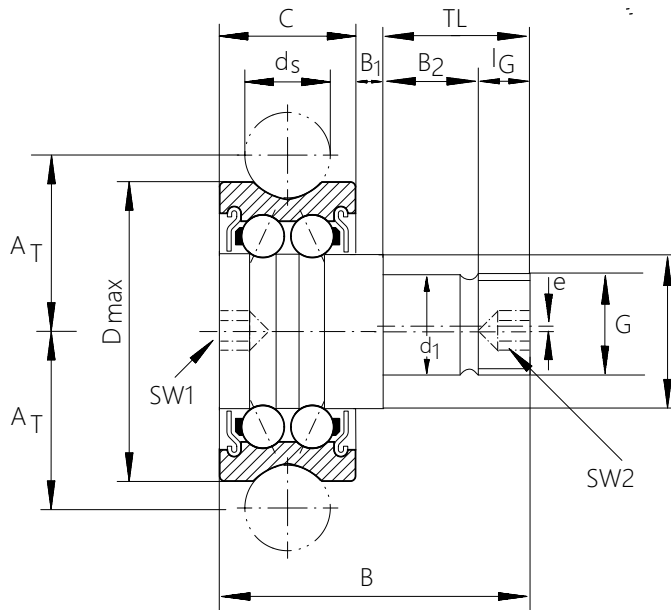

Track Roller No.	Mass	Dimensions									Load Ratings	
		e	ds	D	B	C	d2	d1	G	AT	C	C0
	≈ (g)			mm							KN	(KN)
SRIC5-4	9	-	4	16	14.8	7	8.6	5	M5	9	1.27	0.85
SRIE5-4	9	0.5	4	16	14.8	7	8.6	5	M5	9	1.27	0.85
SRIC5-6-H17	11	-	6	17	17	8	9	5	M5	10.2	1.27	0.82
SRIC6-6	21	-	6	20	20	11	10.6	6	M6	12	3.4	1.7
SRIE6-6	21	0.5	6	20	20	11	10.6	6	M6	12	3.4	1.7
SRIC6-6-H19.5	22	-	6	21	19.5	11	10.2	6	M6	12.25	3.4	1.7
SRIC6-6-H18	22	-	6	22	18	10	10.2	6	M6	12.75	3.4	1.7
SRIC8-8	33	-	8	24	26	11	12.3	8	M8	14.75	5.36	2.76
SRIE8-8	33	0.5	8	24	26	11	12.3	8	M8	14.75	5.36	2.76
SRIC12-10	99	-	10	35	33	15.9	18	12	M12	20.65	8.9	4.7
SRIE12-10	99	0.5	10	35	33	15.9	18	12	M12	20.65	8.9	4.7
SRIC8-6-H20	30	-	6	24	20	11	12.3	8	M8	14	5.36	2.76
SRIC8-6-H25.2	34	-	6	24	25.2	11	12.3	8	M8	14	5.36	2.76
SRIE6-6-H21.5	22	0.5	6	21	21.5	11	10.2	6	M6	12.25	3.4	1.7
SRIC6-6-H19.4	29	-	6	24	19.4	11	12.3	6	M6	14	5.36	2.76
SRIE6-6-H19.4	29	0.6	6	24	19.4	11	12.3	6	M6	14	5.36	2.76

### Note:

1. For the dimension B1,B2,B3,IG,SW1,SW2 , please checking with us before ordering.
2. The sealing solution standard is shields on both side. Seals is also available.
3. The standard grease is Kyodo Yushi Multemp SRL grease.
4. Stand cage material is nylon 66. Steel cage is available for high and low temp application.
5. Tolerance standard is Normal and P6.
6. Runout is below 0.02mm. Spacing hole tolerance is ±0.02.
7. Internal clearance is normal.
8. Roller material standard is 100Cr6( 52100 ) bearing steel. 440C stainless steel on request.
9. MOQ order is 1000pcs.
10. Standard lead time is 60 working days.

Shanghai chenghui (C&H) Bearing Co.,Ltd

2-1709, No 289, Zheqian Road, Pudong, Shanghai, China

Tel: +86 (0) 21 58356710 Fax: +86 (0) 21 58356720

E-mail: jason@chenghuibearing.com / chenghui-china.com



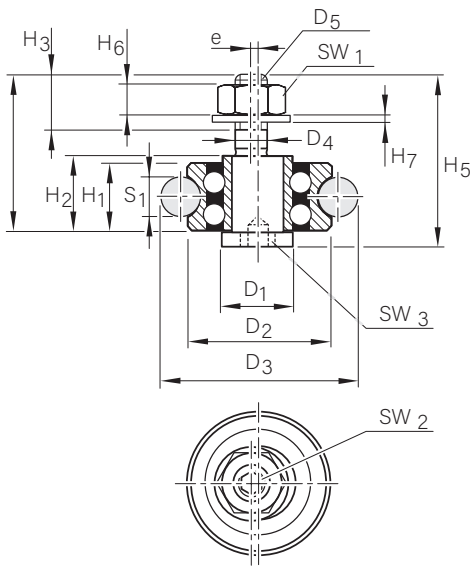

Cam Rollers with Eccentric Spigots

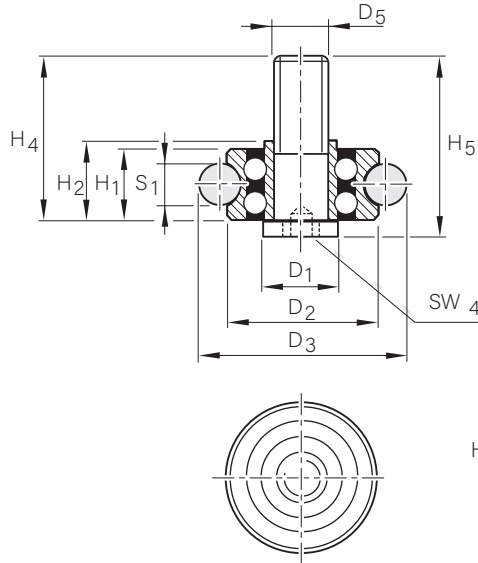

Cam Rollers with Concentric Spigots

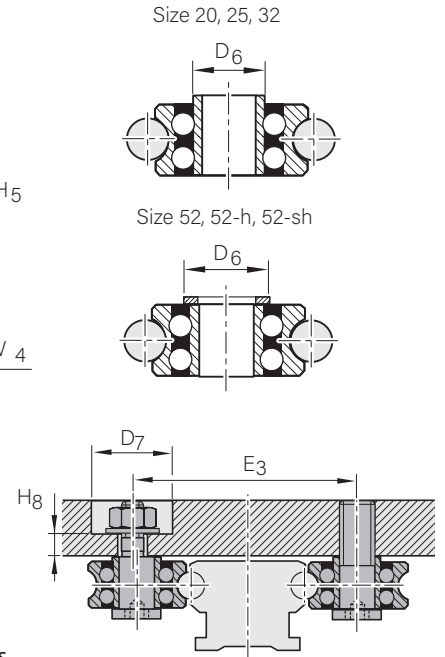

Size Version	Dimensions (mm)																Part number	Type	permissible load		E <sub>3</sub>	D <sub>7</sub>	H <sub>8</sub>	Track Roller No							
	D <sub>1</sub>	D <sub>2</sub>	D <sub>3</sub>	D <sub>4</sub>	D <sub>5</sub>	D <sub>6</sub>	H <sub>1</sub>	H <sub>2</sub>	H <sub>3</sub>	H <sub>4</sub>	H <sub>5</sub>	H <sub>6</sub>	H <sub>7</sub>	SW <sub>1</sub>	SW <sub>2</sub>	SW <sub>3</sub>			SW <sub>4</sub>	S <sub>1</sub>					e	F <sub>y</sub> max	F <sub>z</sub> max	E <sub>3</sub>	D <sub>7</sub>	H <sub>8</sub>	Roller
	g6			g6																					(N)	(N)	± 0,2				
20	10	16	22	4	M4	9	7	8.5	4.6	16	19.5	3.2	0.8	7	2	2	4	4	0.45	R1900 119 00	Eccentric	350	100	33.8	15	3	LF50/5-4N-2Z				
20	10	16	22	4	M4	9	7	8.5	4.6	16	19.5	3.2	0.8	7	2	2	4	4	0.45	R1900 119 01	Concentric	350	100	33.8	15	3	LF50/5-4N-2Z				
25	10	17	27	4	M4	9	7	8.5	5.5	17.4	21.4	3.2	0.8	7	2	2	4	6	0.45	R1900 125 00	Eccentric	350	100	39.8	15	3.6	LF50/5-6N-2Z				
25	10	17	27	4	M4	9	7	8.5	5.5	17.4	21.4	3.2	0.8	7	2	2	4	6	0.45	R1900 125 01	Concentric	350	100	39.8	15	3.6	LF50/5-6N-2Z				
32	14	24	34	6	M6	11.8	11	12.5	7	25.5	29	5.2	1.6	10	3	4	5	6	0.9	R1900 132 00	Eccentric	550	180	54	18	5.5	LF50/8-6N-2Z				
32	14	24	34	6	M6	11.8	11	12.5	7	25.5	29	5.2	1.6	10	3	4	5	6	0.9	R1900 132 01	Concentric	550	180	54	18	5.5	LF50/8-6N-2Z				
52	20	35	51.3	10	M10	19	19	17.9	11	36.5	41.5	8.4	2	16	4	6	8	10	0.9	R1900 152 00	Eccentric	2500	700	83.3	30	7.3	LF5201-10 2Z				
52	20	35	51.3	10	M10	19	19	17.9	11	36.5	41.5	8.4	2	16	4	6	8	10	0.9	R1900 152 01	Concentric	2500	700	83.3	30	7.3	LF5201-10 2Z				
52-h	20	42	58	10	M10	19	19	21	11	44.3	50.3	8.4	2	16	4	6	8	10	0.9	R1900 152 10	Eccentric	2600	800	90	30	11.8	LF5301-10 2Z				
52-h	20	42	58	10	M10	19	19	21	11	44.3	50.3	8.4	2	16	4	6	8	10	0.9	R1900 152 11	Concentric	2600	800	90	30	11.8	LF5301-10 2Z				
52-sh	25	47	63.3	12	M12	24	19	21	13	44.3	50.3	10.8	2.5	18	6	8	10	10	0.9	R1900 152 20	Eccentric	5300	1600	95	34	9.3	LF5302-10 2Z				
52-sh	25	47	63.3	12	M12	24	19	21	13	44.3	50.3	10.8	2.5	18	6	8	10	10	0.9	R1900 152 21	Concentric	5300	1600	95	34	9.3	LF5302-10 2Z				

E3 (Recommended hole spacing when using the following cam roller guide rails: standard R1921, with slot R1922, flat R1924)

Tolerance for E3 ±0.

**Recommended hole spacing when using the following Cam Roller Guide Rails:**

- Standard R1921
- With T-slot R1922
- Low-profile R1924-

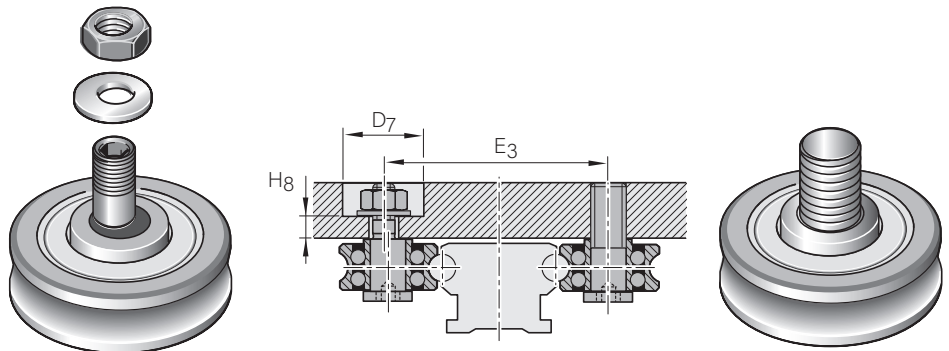

Shanghai chenghui (C&H) Bearing Co.,Ltd

2-1709, No 289, Zheqian Road, Pudong, Shanghai, China

Tel: +86 (0) 21 58356710 Fax: +86 (0) 21 58356720

E-mail: jason@chenghuibearing.com / chenghui-china.com