

Overall

▼ LV ... Guide Wheel..... Vee Bearing

- ◇ LV Series LV bearings can be widely used in the cylindrical track or " V " profile track with an angle of 120 degrees. Different from the series LFR bearings, series LV bearings are more adaptable to the different track sizes. Each type can be applied with a larger range of track diameters.They are widely used for the heavy-duty track, mobile equipment wire straightening machine and so on.
- ◇ Bearings take the internal structure design of double row angular contact ball bearings and have a thick-walled outer ring, so the bearings can accommodate higher loads.
- ◇ Bearings are made of the high-quality bearing steel, processed by heat treatment and precision grinding, and are filled with a long service life, high-grade and multipurposes grease. Bearings take the metal shields to prevent the dust.
- ◇ The bearings have an undercut on its bottom of groove on the outer ring. If the application disallow this undercut, we can meet customer's technical requirement. Also can accept the bearings with various angle of " V " profile.

▼ Characteristics of Guide System that series LV wheels are applied

- ◇ Low resistance, long service life, widely-use

The roughness of the " V " , profile surface can be reached to Ra0.32 processed by precision grinding. The bearings have good parallelism between the " V " profile groove and the mounting planes of inner ring relatively. When bearings working, the stresses between the bearing and cylindrical track is in good-distribution and the friction resistance is low.

- ◇ Easy installation

After bearing assembled the concentric or eccentric pivot, installation will be convenient. To adjust the eccentric one's eccentricity, the bearing can get the fitting preload

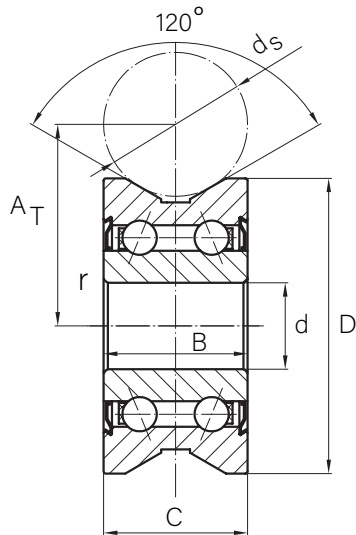

Part Number	Dimensions (mm)								Load Rating(N)				Limiting Speed	Weight	Cross No.
	Linear shaft dia.	Bore dia.	Outside dia.	Inner ring width	Outer ring width	shaft center to bore	Chamfer	Angle	Effective dynamic load rating as track	Effective static load rating as track roller	Maximum dynamic load rating as track	Maximum static load rating as track			
	ds	d	D	B	C	AT	r	α	Crw	Corw	Fr per	F0r per			
	mm	mm	mm	mm	mm	mm	mm	degree	N	N	N	N			
LV20/7-2Z	10	7	22	11	11	14.5	0.3	120	2450	1620	2350	4150	20000	0.017	RV20/7-10
LV20/8-2Z	10	8	30	14	14	18.1	0.3	120	4490	2700	11000	19800	19000	0.049	RV20/8-10
LV202-38-2Z	10	15	38	17	17	22.25	0.5	120	7290	4550	10200	17900	14000	0.087	RV202/15.38-10
LV202-40-2Z	10	15	40	18	18	22	0.5	120	7950	4950	14500	26500	14000	0.11	RV202/15.40-10
LV201-2Z	20	12	41	20	20	28	0.3	120	8180	5110	17200	31500	14000	0.13	RV201/12-20
LV202-41-2Z	20	15	41	20	20	28	0.5	120	8180	5110	17200	31500	14000	0.116	RV202/15.41-20
LV203-2Z	20	17	58	25	25	35	0.5	120	16580	9200	47000	86000	12000	0.325	RV203/17-20
LV204-57-2Z	30	20	57	22	22	41	0.6	120	16910	9200	47000	86000	12000	0.29	RV204/20.57-30
LV204-58-2Z	30	20	58	25	25	41	0.6	120	16790	9200	40000	72000	12000	0.31	RV204/20.58-30

Note:

- Standard material is GCr15 bearing steel (equivalent 52100/100Cr6/SUJ2) ;
- 440C stainless version on request. Order add suffix "SS440"
- Standard cage material is Nnylon 66. Steel cage on request for high and low temperatue application.
- Standard sealing solution is with shields on both sides. Seals on request.
- Standard grease is Kyodo Yushi Multemp SRL.
- Standard tolerance is P0. Runout accuracy is P6.
- Standard internal clearance is Normal.
- MOQ is 1000pcs.
- Standard lead time: 60 days.

Shanghai Chenghui (C&H) Bearing Co., Ltd
 2-1709, No 289, Zheqiao Road, Pudong, Shanghai, China
 Tel: +86 (0) 21 5835 6710 Fax: +86 (0) 21 5835 6720
 E-mail: jason@chenghuibearing.com / www.chenghuibearing.com

SVA Studded Track Roller

thru-hole type, 120 degree V groove profile outside running surface

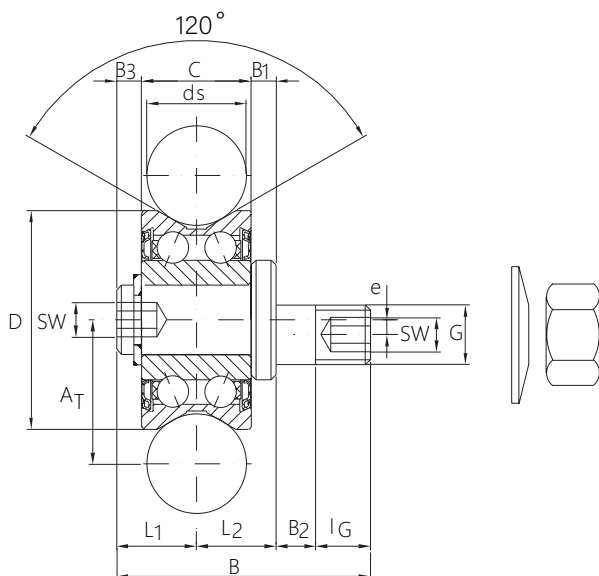

Part Number	Dimensions (mm)														Load ratings(N)				Weight kg	Roll No C&H	Interchange NIKO
	e	ds	D	C	B	AT	L1	L2	IG	B1	B2	B3	SW	G	Cw	Cow	Fr per	F0r per			
SVAC22	-	10	22	11	26	14.5	8.5	8	5.5	3	4	3	3	M6	2,450	1,620	2,350	4,150	0.028	LV20/7-2Z	RV22C
SVAE22	1.5	10	22	11	26	14.5	8.5	8	5.5	3	4	3	3	M6	2,450	1,620	2,350	4,150	0.028	LV20/7-2Z	RV22E
SVAC30	-	10	30	14	33	18.1	9.5	9	8	2.5	6	2	4	M8	4,490	2,700	11,000	19,800	0.069	LV20/8-2Z	RV30C
SVAE30	1.5	10	30	14	33	18.1	9.5	9	8	2.5	6	2	4	M8	4,490	2,700	11,000	19,800	0.069	LV20/8-2Z	RV30E
SVAC38	-	10	38	17	42	22.3	11	11	12	2.5	8	3	5	M10	7,290	4,550	10,200	17,900	0.145	LV202-38-2Z	RV38C
SVAE38	2	10	38	17	42	22.3	11	11	12	2.5	8	3	5	M10	7,290	4,550	10,200	17,900	0.145	LV202-38-2Z	RV38E
SVAC41	-	20	41	20	47	28	15	13	13	5	6	3	6	M12	8,180	5,100	17,200	31,500	0.19	LV201-2Z	RV41C
SVAE41	2	20	41	20	47	28	15	13	13	5	6	3	6	M12	8,180	5,100	17,200	31,500	0.19	LV201-2Z	RV41E
SVAC58	-	20	58	25	59	35	17	19	13	4	11	6	6	M16	16,580	9,200	47,000	86,000	0.46	LV203-2Z	RV58C
SVAE58	2.5	20	58	25	59	35	17	19	13	4	11	6	6	M16	16,580	9,200	47,000	86,000	0.46	LV203-2Z	RV58E

Note:

1. Washer and nut are not included. Order on request.
2. Standard material is GCr15 bearing steel (equivalent 52100/100Cr6/SUJ2) ; 440C stainless steel version on request. Order add suffix "SS440"
3. Standard cage material is Nnylon 66. Steel cage on request for high and low temperatue application.
4. Standard sealing solution is with shields on both sides. Seals on request.
5. Standard grease is Kyodo Yushi Multemp SRL.
6. Standard tolerance is P0. Runout accuracy is P6.
7. Standard internal clearance is Normal.
8. MOQ is 1000pcs.
9. Standard lead time: 60 days.

Shanghai Chenghui (C&H) Bearing Co., Ltd
 2-1709, No 289, Zheqiao Road, Pudong, Shanghai, China
 Tel: +86 (0) 21 5835 6710 Fax: +86 (0) 21 5835 6720
 E-mail: jason@chenghuibearing.com / www.chenghuibearing.com

SVI Studded Track Roller

integral stud type, 120 degree V groove profile outside running surface

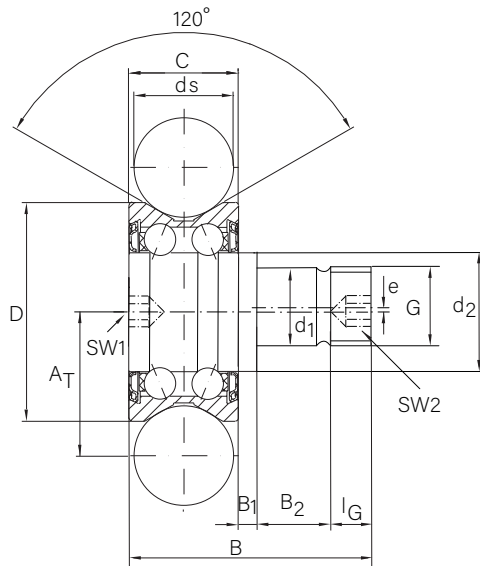

Part Number	Dimensions (mm)											Load ratings(N)				Weight kg
	e	ds	D	C	B	A _T	B ₁	B ₂	l _G	SW	G	C _w	C _{ow}	Fr per	F _{0r} per	
SVIC22	-	10	22	11	24	14.5	3	4	5.5	3	M6	2,450	1,620	2,350	4,150	0.028
SVIE22	1.5	10	22	11	24	14.5	3	4	5.5	3	M6	2,450	1,620	2,350	4,150	0.028
SVIC30	-	10	30	14	31	18.1	2.5	6	8	4	M8	4,490	2,700	11,000	19,800	0.069
SVIE30	1.5	10	30	14	31	18.1	2.5	6	8	4	M8	4,490	2,700	11,000	19,800	0.069
SVIC38	-	10	38	17	40	22.3	2.5	8	12	5	M10	7,290	4,550	10,200	17,900	0.145
SVIE38	2	10	38	17	40	22.3	2.5	8	12	5	M10	7,290	4,550	10,200	17,900	0.145
SVIC41	-	20	41	20	44	28	5	6	13	6	M12	8,180	5,100	17,200	31,500	0.19
SVIE41	2	20	41	20	44	28	5	6	13	6	M12	8,180	5,100	17,200	31,500	0.19
SVIC58	-	20	58	25	53	35	4	11	13	6	M16	16,580	9,200	47,000	86,000	0.46
SVIE58	2.5	20	58	25	53	35	4	11	13	6	M16	16,580	9,200	47,000	86,000	0.46

Note:

1. Washer and nut are not included. Order on request.
2. Standard material is GCr15 bearing steel (equivalent 52100/100Cr6/SUJ2) ; 440C stainless steel on request. Order add suffix "SS440"
3. Standard cage material is Nnylon 66. Steel cage on request for high and low temperatue application.
4. Standard sealing solution is with shields on both sides. Seals on request.
5. Standard grease is Kyodo Yushi Multemp SRL.
6. Standard tolerance is P0. Runout accuracy is P6.
7. Standard internal clearance is Normal.
8. MOQ is 1000pcs.
9. Standard lead time: 60 days.

Shanghai Chenghui (C&H) Bearing Co., Ltd

2-1709, No 289, Zheqiao Road, Pudong, Shanghai, China

Tel: +86 (0) 21 5835 6710 Fax: +86 (0) 21 5835 6720

E-mail: jason@chenghuibearing.com / www.chenghuibearing.com